

This Manual Provides Installation and Operation Instructions for the following models:

CAPSTAN 1000

CAPSTAN 300

QUICK CATCH POT PULLER

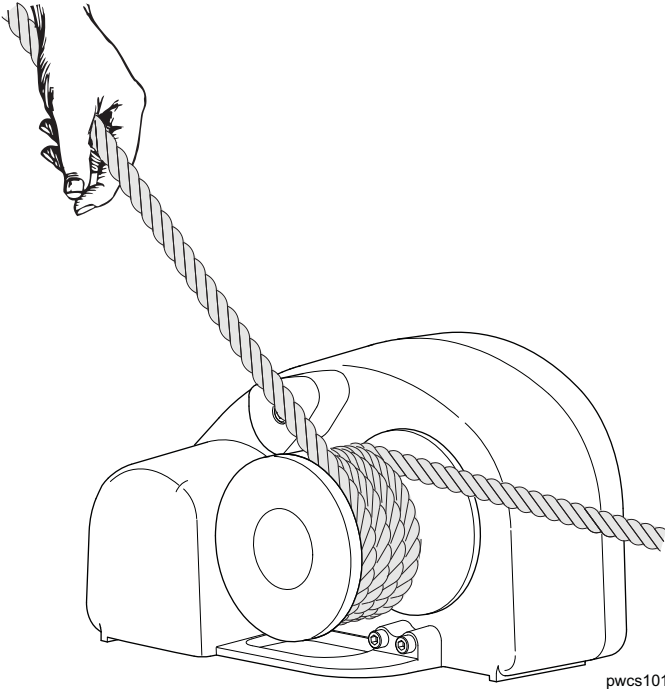

- ◆ *12 Volt Powered Winch*
- ◆ *Powered Lift Assist for anchors, pots and traps.*

*These instructions apply to all models listed. Details and procedures unique to a specific model are labeled appropriately.*

# PROPRIETARY STATEMENT

The *Powerwinch* Capstan is a product of Carefree of Colorado, located in Broomfield, Colorado, USA. The information contained in or disclosed in this document is considered proprietary to Carefree of Colorado. Every effort has been made to ensure that the information presented in the document is accurate and complete. However, Carefree of Colorado assumes no liability for errors or for any damages that result from the use of this document.

The information contained in this manual pertains to the current configuration of the models listed on the title page. Earlier model configurations may differ from the information given. Carefree of Colorado reserves the right to cancel, change, alter or add any parts and assemblies, described in this manual, without prior notice.

Carefree of Colorado agrees to allow the reproduction of this document for use with Carefree of Colorado products only. Any other reproduction or translation of this document in whole or part is strictly prohibited without prior written approval from Carefree of Colorado.

# TABLE OF CONTENTS

<b>Safety Information</b> .....	<b>1</b>
General Safety Information .....	1
<b>Specifications</b> .....	<b>2</b>
Furnished Materials:.....	3
Required Materials (not included with winch) .....	3
<b>Mounting the Unit</b> .....	<b>4</b>
<b>Wiring the Unit</b> .....	<b>5</b>
Testing the Unit .....	6
<b>Operating the Winch</b> .....	<b>7</b>
Loading the Rope .....	7
Lowering the Load.....	7
Retrieving the Load .....	7
Maintenance.....	7
<b>Replacement Parts List</b> .....	<b>8</b>
<b>Warranty</b> .....	<b>10</b>

---

## SAFETY INFORMATION

---

**⚠ WARNING** A WARNING INDICATES A POTENTIALLY HAZARDOUS SITUATION WHICH, IF NOT AVOIDED, COULD RESULT IN DEATH OR SERIOUS INJURY AND/OR MAJOR PROPERTY DAMAGE.

---

**⚠ CAUTION** A CAUTION INDICATES A POTENTIALLY HAZARDOUS SITUATION THAT MAY CAUSE MINOR TO MODERATE PERSONAL INJURY AND/OR PROPERTY DAMAGE. IT MAY ALSO BE USED TO ALERT AGAINST UNSAFE PRACTICES.

**NOTE:** A note indicates further information about a product, part, or step.

*Tip:* A tip provides helpful suggestions.

### GENERAL SAFETY INFORMATION

**The following Safety Precautions Must be Followed at ALL Times**

**Failure to follow the warnings and cautions in this manual could result in serious injury and/or property damage.**

Thoroughly read the manuals furnished with this product and be familiar with the controls. Do not allow individuals to operate the winch without understanding the safe operation and procedures for the equipment.

---

## ⚠ WARNINGS

- ⚠** ALWAYS unplug the wiring harness before attempting to install, relocate, service or perform maintenance on the unit.
- ⚠** NEVER use the winch to lift or move people or animals.
- ⚠** NEVER use the winch for overhead lifting.
- ⚠** NEVER attempt to pull a load greater than the rated load of the winch.
- ⚠** NEVER use the winch to exclusively hold, support or permanently secure the load. Use separate straps to support the load.
- ⚠** ALWAYS stand away from the winch during operation. ALWAYS stand clear of the area behind and between the load or anchor point and the winch. Serious injury could occur if the rope breaks.
- ⚠** ALWAYS keep hands clear of the drum area.
- ⚠** ALWAYS wear leather gloves when handling the rope.
- ⚠** NEVER wear loose fitting clothes, scarves, ties or jewelry when operating the winch. Loose clothing can become caught in moving parts.
- ⚠** ALWAYS tie off the anchor to a secure mount (e.g. a deck cleat) for storage and after lowering the anchor. NEVER use the winch to tie off the anchor.
- ⚠** ALWAYS use the recommended rope.

SPECIFICATIONS

**Davit/Bow Roller**

This product requires the use of a closed loop davit or bow roller. Davit or bow roller must be installed prior to installing inch to ensure proper performance.

**⚠ CAUTION** USE OF A DAVIT WITH AN OPEN LOOP IS NOT RECOMMENDED WITH THIS PRODUCT. USE A DAVIT WITH A CLOSED LOOP TO PREVENT SERIOUS PERSONAL INJURY AND/OR PROPERTY DAMAGE.

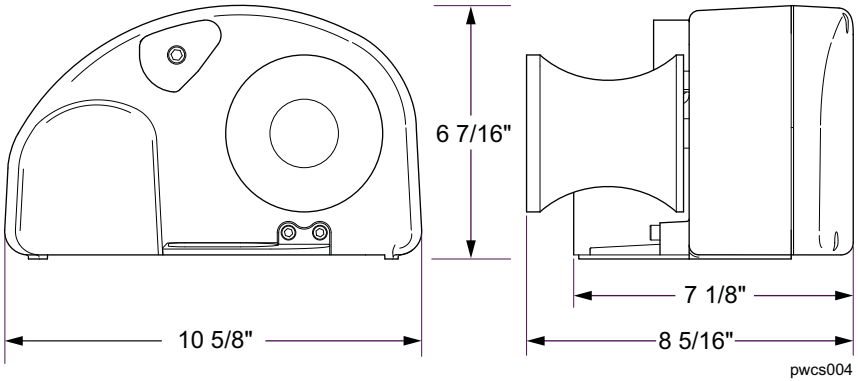

Model	Maximum Pull	Rope Size*	Voltage	Circuit Breaker	Unit Weight
Capstan 1000	1000 lbs.	1/2-3/4"	12VDC	80 amps	23 lbs.
Capstan 300	300 lbs.	1/2-5/8"	12VDC	25 amps	20 lbs.
Quick Catch Pot Puller	200 lbs.	Up to 5/8"	12VDC	80 amps	19 lbs.

\* Recommended rope is three (3) strand, medium lay, premium nylon.

## FURNISHED MATERIALS:

Capstan 1000		Capstan 300		Quick Catch Pot Puller	
qty	Description	qty	Description	qty	Description
1	Winch	1	Winch	1	Winch
3	5/16-18 x 3.5 Stud	3	5/16-18 x 3.5 Stud	3	5/16-18 x 3.5 Stud
3	5/16 Lock Washer	3	5/16 Lock Washer	3	5/16 Lock Washer
3	5/16 Flat Washer	3	5/16 Flat Washer	3	5/16 Flat Washer
3	5/16-18 Nut	3	5/16-18 Nut	3	5/16-18 Nut
1	80A Circuit Breaker	1	25A Circuit Breaker	1	80A Circuit Breaker
1	Foot Switch	1	Foot Switch	1	Foot Switch
1	Mounting Template	1	Mounting Template	1	Mounting Template

## REQUIRED MATERIALS (NOT INCLUDED WITH WINCH)

- Loctite 242 thread locker or equivalent.
- Silicone sealant.

**ELECTRICAL INSTALLATION – CAPSTAN 1000 & QUICK CATCH POT PULLER**

These items are furnished by the installer.

Qty	Description	
	6 awg RED Wire Class 105°C	Wire is used for the "run" wire from winch to switch, battery to switch and battery to winch. Length is based on installation.
	6 awg BLACK Wire Class 105°C	
7	5/16" 6 awg ring terminals	
5	1/4-20 x 1/2 Screws	Screws and nuts should be stainless steel to avoid rust and corrosion.
5	1/4-20 Nuts	
a/r	Wire ties	
2 ft	1" diameter heat shrink	
2 ft	2" diameter heat shrink	

**ELECTRICAL INSTALLATION – CAPSTAN 300**

These items are furnished by the installer.

Qty	Description	
	8 awg RED Wire Class 105°C	wire is used for the "run" wire from winch to switch, battery to switch and battery to winch. Length is based on installation.
	8 awg BLACK Wire Class 105°C	
7	5/16" 8 awg ring terminals	
5	1/4-20 x 1/2 Screws	Screws and nuts should be stainless steel to avoid rust and corrosion.
5	1/4-20 Nuts	
a/r	Wire ties	
2 ft	1" diameter heat shrink	
2 ft	2" diameter heat shrink	

**MOUNTING THE UNIT**

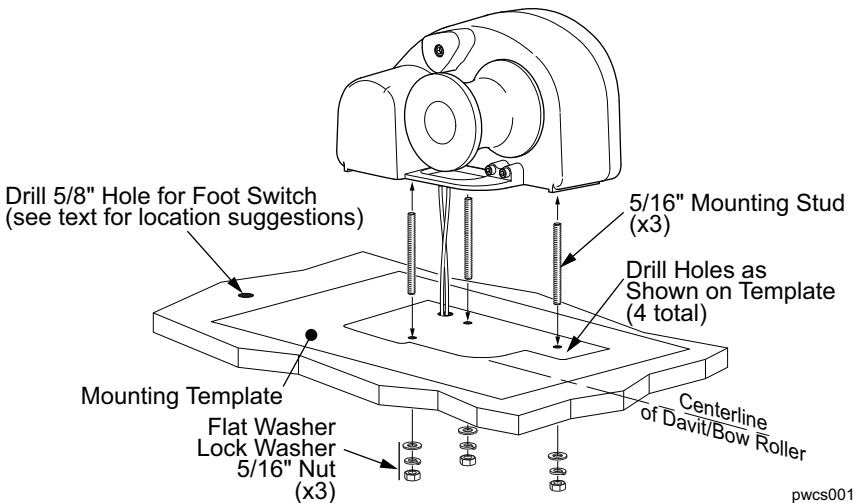
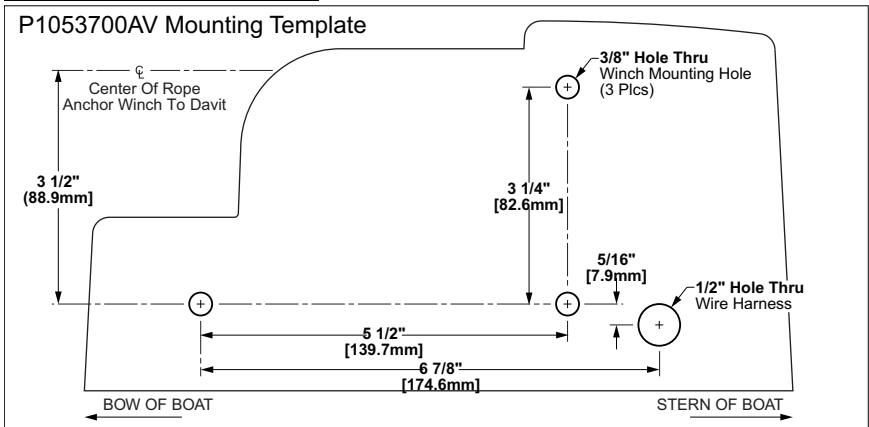

1. Place the mounting template on the deck in the desired location and secure with tape.
  - a. The centerline of the capstan must line up with the centerline of the davit or bow roller.
2. Drill the holes as marked on the template.
3. Remove the template.
4. Use a small amount of thread locker on the end of the studs then thread the 5/16-18 x 3 1/2" studs into the winch. Hand tighten until snug.
5. Align the winch and the studs with the holes in the deck. Insert the wires through the hole in the deck. Lower the winch to the deck.
6. Under the deck, secure the winch to the deck use one (1) each 5/16 flat washer, 5/16 lock washer and 5/16 nut on each of the studs. Tighten the nuts to secure the winch to the deck.

## WIRING THE UNIT

### ⚠️ WARNINGS

- ⚠️ ALWAYS disconnect the battery before working on electrical equipment.
- ⚠️ ALWAYS use the recommended wire size and rated circuit breakers. Failure to use the furnished and recommended sizes can cause a fire hazard and void warranty.
- ⚠️ When routing the wiring, avoid sources of heat.
- ⚠️ When routing the wiring, avoid sharp edges that can cut or fray the wire insulation.

1. Locate a suitable location for the switch.
  - Location should be easily accessible when handling the rope from the capstan.
  - Locate the switch outside the normal traffic patterns. This is to avoid the switch being accidentally stepped on or tripped over.

2. Drill a 5/8" hole through the mounting surface.
3. If attached, unscrew the rubber cap from the top of the switch and install the switch from the underside of the deck.
4. Fully thread the cap back onto the switch. Tighten the jam nut from below deck to secure the switch.
5. Connect the two (2) red wires to the switch.

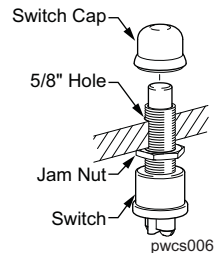

6. At the winch, terminate the wires from the winch with 5/16" ring terminals.
7. Route one BLACK wire from the winch to the battery location. Be sure to allow adequate wiring to make connections, allow the wire to have some slack when routing. Secure the wires with wire ties.

*Tip: Before making the mechanical connection, slide a 2 1/2" piece of the shrink tubing over one wire. Make the connection then slide the wrap over the connection. Lightly heat the wrap until it shrinks around the terminals.*

8. At the winch, terminate the BLACK wire with a 5/16" ring terminal. Attach the new wire to the motor BLACK wire with a 1/4 -20 screw and nut and shrink wrap.
9. At the battery, terminate the BLACK wire with a 3/8" ring terminal. Attach the new wire to the NEGATIVE (-) terminal of the battery.
10. Route one RED wire from the winch to the switch location. Be sure to allow adequate wiring to make connections, allow the wire to have some slack when routing. Secure the wires with wire ties.
11. Terminate each end of the RED wire with 5/16" ring terminals.
12. Connect the motor GREEN wire to the RED wire with a 1/4 -20 screw and nut and shrink wrap.
13. At the switch position, connect the RED wire to one of the short wires from switch with a 1/4 -20 screw and nut and shrink wrap.

14. Route one RED wire from the battery to the switch location. Be sure to allow adequate wiring to make connections, allow the wire to have some slack when routing. Secure the wires with wire ties.
15. At the switch terminate the new wire with a 5/16 ring terminal and attach to the second short wire from the switch with a 1/4 -20 screw and nut and shrink wrap.
16. At the battery terminate the RED wire with a #10 ring terminal. Attach the wire to the "AUX" post of the circuit breaker.
17. Attach the circuit breaker to the POSITIVE (+) terminal of the battery.

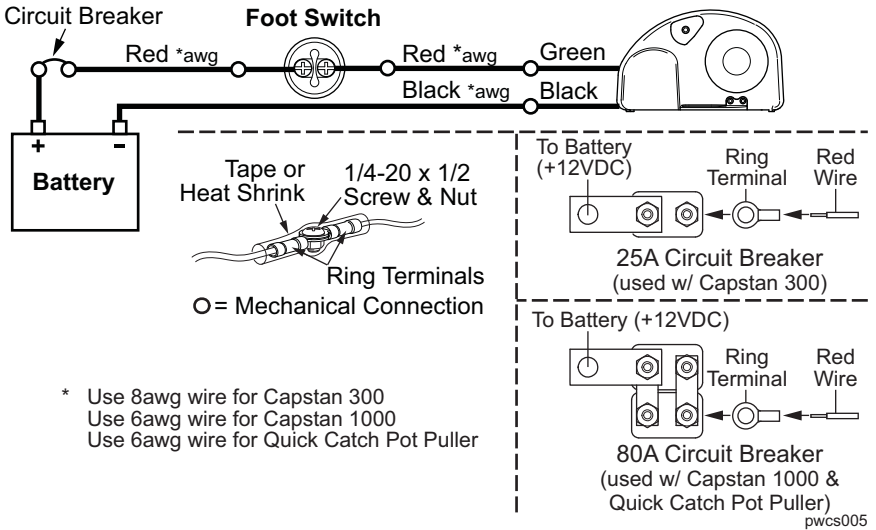

**TESTING THE UNIT**

1. Ensure that all connections are secure and correct.
2. With no rope on capstan, press down the switch. If the motor runs but the capstan does not turn, motor wires are reversed. Reverse the red and black wires at the motor leads.



## OPERATING THE WINCH

The Capstan can be used to retrieve anchors, traps or pots; these are referred to as the "load" in the directions below.

### LOADING THE ROPE

1. Thread the rope through the davit or bow roller and pull back to the winch.
2. Wrap the rope counterclockwise 4-5 wraps around the capstan.

**⚠ CAUTION** ALWAYS SECURE THE ROPE TO A DECK CLEAT OR SIMILAR DEVICE. DO NOT USE THE WINCH TO TIE OFF THE LOAD.

**⚠ CAUTION** ALWAYS USE THE RECOMMENDED ROPE (SEE PAGE 2). USE OF DIFFERENT ROPE CAN CAUSE PROPERTY DAMAGE AND PERSONAL INJURY.

### LOWERING THE LOAD

1. Turn boat into wind and place boat motors in neutral.
2. After the boat has stopped all forward progress, release the rope from the deck cleat. Allow the load to free fall to the sea bed.

**⚠ CAUTION** NEVER USE THE WINCH TO LOWER THE LOAD OR TO BRAKE THE LOAD DURING FREE FALL. THIS CAN RESULT IN SERIOUS DAMAGE TO THE GEAR TRAIN.

3. After the desired amount of rope has been released, tie the rope off to a deck cleat. **DO NOT** use the winch to tie-off the anchor.
4. For anchors, place the boat's motors in neutral and allow the boat to drift back and set the anchor in the sea bed.

### RETRIEVING THE LOAD

1. Untie the rope from the deck cleat.
2. Align bow of boat with load.
3. Place the boat's motors in forward and move boat slowly toward the anchor point.
4. Press the winch switch and pull the rope hand over hand.

**NOTE:** The rope must be kept under tension for the winch to work properly.

5. After the load is secured, tie the rope off to a deck cleat. **DO NOT** use the winch to tie-off the load.

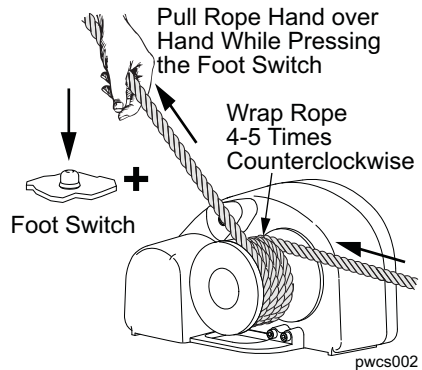

### MAINTENANCE

Following each boat outing, flush exterior of winch with fresh water. Use only mild detergents to clean exterior. Use of solvents can cause damage to the finishes and seals, as well as void product warranty

Every 6 months inspect capstan for wear. Replace any worn components.

Check rope periodically for abrasion or deep cuts. Never splice an old rope with a new rope. If replacement is necessary, use only Powerwinch recommended rope.

Check electrical connections every 6 months for corrosion. Replace any connection or wire which is damaged, corroded, frayed or worn.

REPLACEMENT PARTS LIST

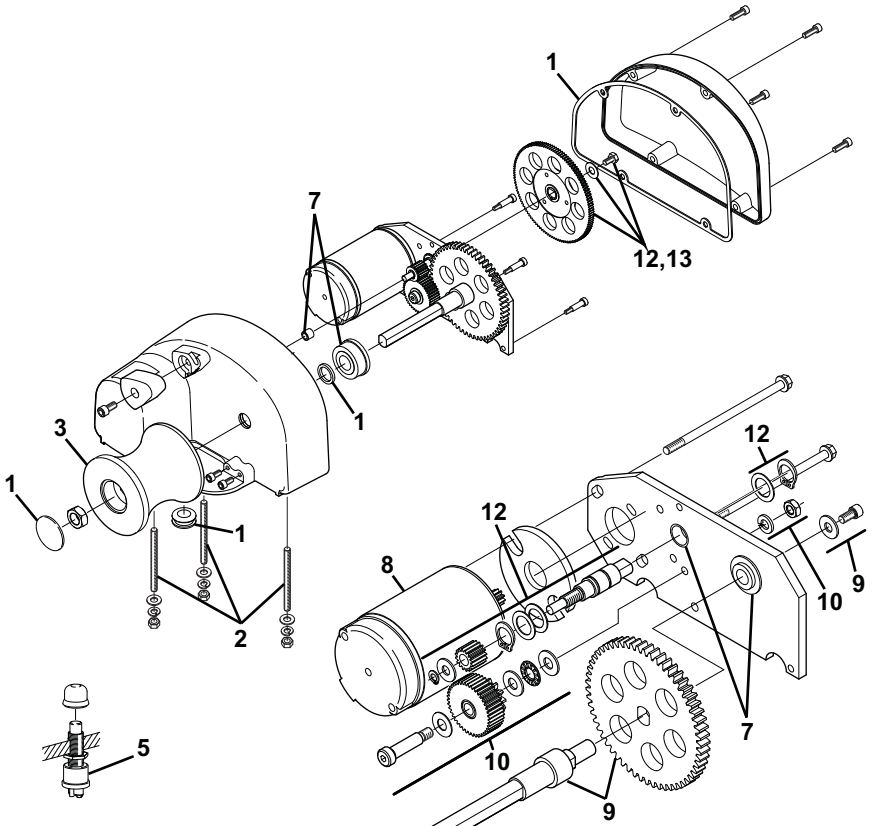

**CAPSTAN 1000**

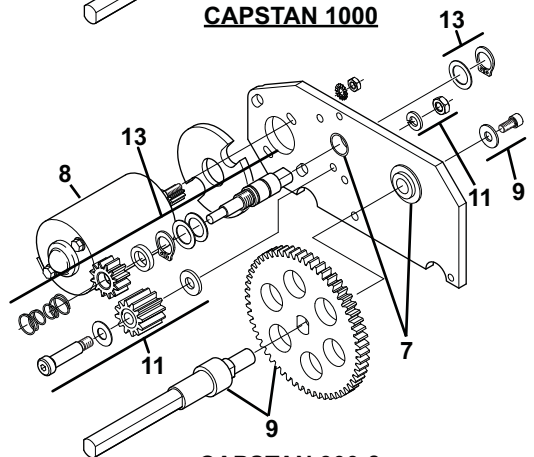
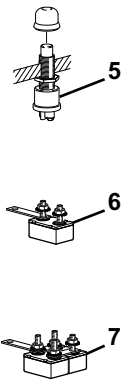

**CAPSTAN 300 &  
QUICK CATCH POT PULLER**

<b>Item</b>	<b>Description</b>	<b>Capstan 1000</b>	<b>Capstan 300</b>	<b>Quick Catch Pot Puller</b>	<b>Notes</b>
1	Seal & Gasket Kit	P10346	P10346	P10346	
2	Mounting Kit	P10728	P10728	P10728	
3	Capstan Kit	R001461	R001461	R001461	1
4	Foot Switch	P7817600AJ	P7817600AJ	P7817600AJ	
5	Circuit Breaker, 25A	--	P1027600AJ	--	
6	Circuit Breaker, 80A	P1066800AJ	--	P1066800AJ	
7	Bearing Kit	P10725	P10343	P10343	
8	Motor Kit	R001462	R001451	R001463	
9	Capstan Shaft	R001456	R001456	R001456	
10	Locking Gear Kit	P10731	--	--	
11	Locking Gear Kit	--	R001453	R001453	
12	Intermediate Shaft	P10723			
13	Intermediate Shaft	--	R001446	R001446	

Notes: 1. Capstan kit (item 3) includes seal and nut.

**FOR YOUR RECORDS:**

**DEALER/INSTALLER**

**NAME:** \_\_\_\_\_

**ADDRESS:** \_\_\_\_\_

**PHONE:** \_\_\_\_\_

**PURCHASE DATE:** \_\_\_\_\_

**PART NUMBER:** \_\_\_\_\_

**SERIAL NUMBER:** \_\_\_\_\_

**PRODUCT NAME  
OR DESCRIPTION:** \_\_\_\_\_

***Retain your original proof of purchase.  
It is required for all warranty repairs and returns.***

## WARRANTY

Carefree of Colorado (hereafter referred to as Carefree) warrants to the FIRST retail Purchaser that the Powerwinch Product described in this manual is free of defects in material and workmanship within the terms and conditions as set forth below. Carefree's obligation under this warranty is limited to the repair or replacement, at Carefree's option, of any defective component within the stated warranty period. THIS WARRANTY IS NOT TRANSFERABLE.

### 1. DURATION

- a) 2 years on parts and labor.
- b) Carefree will pay the transportation charges for return shipment to the purchaser of any product received for legitimate warranty repair.

Warranty duration is not extended by the length of time the product is not in use or the time that the purchaser is deprived the use of the product. The duration of coverage is determined by the date of the original product purchase, not the date of repairs.

### 2. WHAT IS COVERED UNDER THIS WARRANTY

Defects in the manufacturer's material and workmanship of product under normal use, and which occur within the duration of the warranty period.

### 3. WHAT IS NOT COVERED UNDER THIS WARRANTY

- a) Improper installation and/or any consequent damage or failure that results from improper installation of the product.
- b) Normal wear.
- c) Conditions that are not related to the material or workmanship of the product: including any failure that results from an accident, wind, rain, or other acts of God.
- d) Purchaser's abuse, including but not limited to neglect; failure to operate, use or maintain the product in accordance with the instructions provided with the product.
- e) Any component not sold or manufactured by Carefree.
- f) Any failure that results from the use of another manufacturer's product with a Carefree product that is not specifically approved by Carefree.
- g) Any incidental, indirect, or consequential loss, damage or expense that may result from any defect, failure or malfunction of the product.
- h) The removal or alteration of any product component or device. In the event of such removal or alteration, this warranty is void.
- i) Any expense related to delivery or pick-up of product to/from the service dealer.

### 4. RESPONSIBILITIES OF THE PURCHASER

IN ORDER FOR THE WARRANTY TO BE HONORED, THE PURCHASER MUST HAVE PROOF OF PURCHASE. FAILURE TO PROVIDE THE REQUIRED DOCUMENTATION MAY DELAY OR VOID ANY WARRANTY CLAIM.

- a) Retain dated proof of purchase for the product, and provide it as requested.
- b) Perform "Periodic Maintenance" as specified in Owners Manual.
- c) Use reasonable care in maintenance, operation, use and storage of the product in accordance with the instructions contained in the owner's manual.

**THIS WARRANTY GIVES THE OWNER SPECIFIC LEGAL RIGHTS. THE LAWS OF CERTAIN JURISDICTIONS MAY GRANT THE OWNER ADDITIONAL RIGHTS AND PRIVILEGES.** Except as set forth above; Carefree makes no warranty, whether statutory or otherwise, including without limitation, any warranty of merchantability or fitness for a particular purpose. Carefree shall have no liability except to repair, replace or adjust defective products and parts. Carefree specifically excludes any liability, whether in contract, tort or otherwise, for personal injury, property damage, economic or consequential losses. Carefree has not authorized any person or company to alter the terms of this warranty.

It is Carefree of Colorado's policy and practice to continuously improve the company's products and services. Therefore, Carefree reserves the right to make changes in design and components, without notice, whenever it is believed the quality of the product will be improved, but without incurring any obligation to incorporate such improvements in any product which has been shipped or in service.